

# Honda Engines

*A genuine part can make the difference*

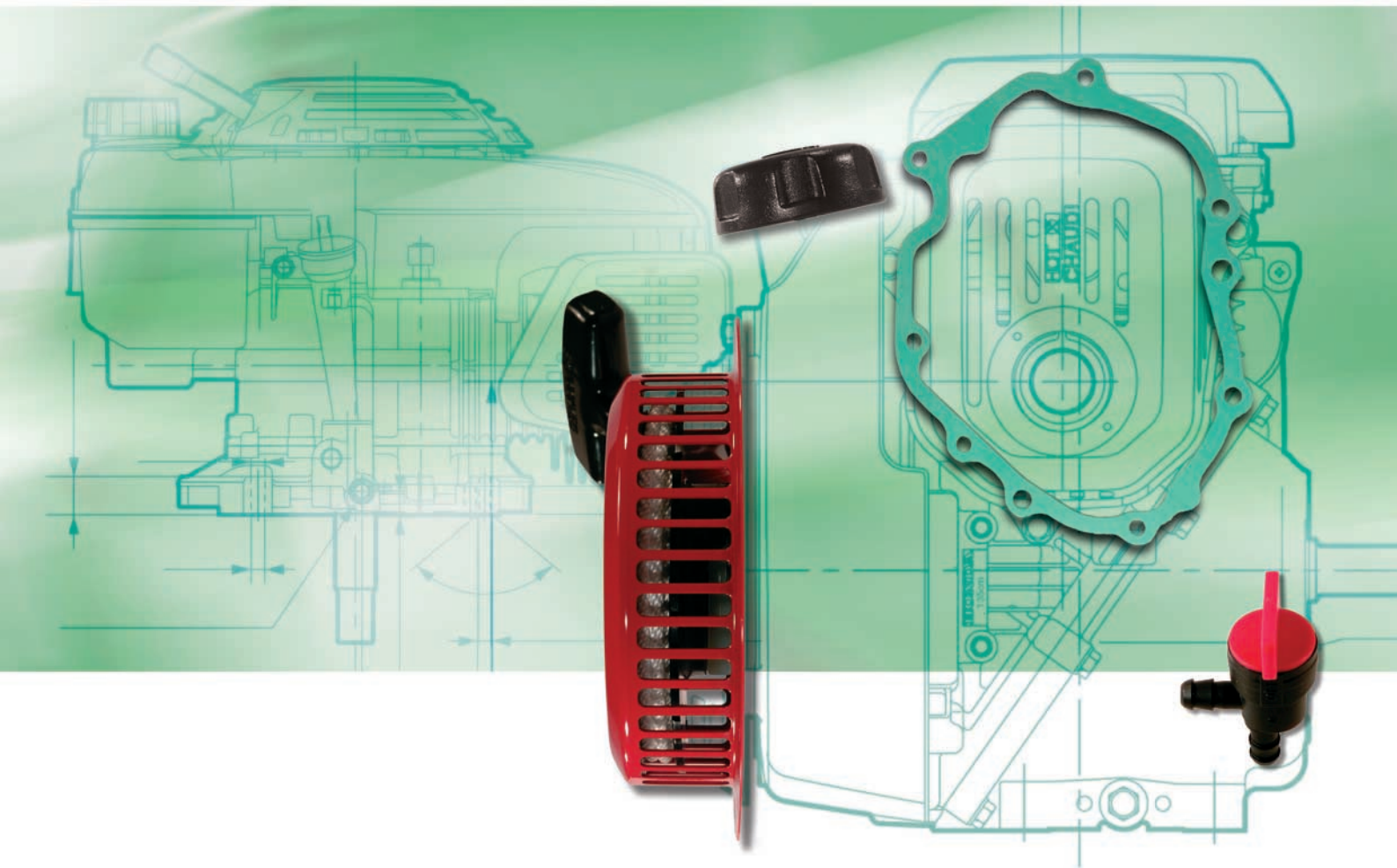

# Engine models



Engine model	Model code	Engine serial no	
		From	To
G 100K1	G100-	2000001	2424874
G 100K2	G100-	3000001	9999999
G 150	G150-	1000001	9000000
G 150K1	G150-	9100001	9999999
G 200	G200-	1000001	9000000
G 200K1	G200-	9100001	9999999
GC 135	GCAJ-	1000001	9999999
GC 160	GCAH(A)-	1000001	9999999
GX 22	GCAF-	1000001	9999999
GX 31	GCAJ-	1000001	9999999
GX 25	GCAAM-	1000001	9999999
GXH 50	GCAL-	1000001	9999999
GX 100	GCANM-	1000001	9999999
GX 120K1	GC01-	2000001	9999999
GX 160K1	GC02-	2000001	9999999
GX 200	GCAE-	1000001	9999999
GX 240K1	GC04-	3000001	9999999
GX 270	G CAB-	1000001	9999999
GX 340K1	GC05-	2000001	9999999
GX 390K1	GCAA-	2000001	9999999
GX 360K1	GA01-	1100001	9999999
GX 640	GAAD-	1000001	9999999
GX 610	GCAC-	1000001	1999999
GX 620	GCAD-	1000001	1999999
GX 610K1	GCAC-	2000001	9999999
GX 620K1	GCAD-	2000001	9999999
GX 670	GCAM-	1000001	9999999
GV 100K1	GV100-	2000001	2999999
GV 100K2	GV100-	9100001	9999999
GCV 135	GJAF-	1000001	9999999
GCV 135E	GJAFE-	1000001	9999999
GCV 160A	GJAEA-	1000001	9999999
GCV 160	GJAE-	1000001	9999999
GCV 520	GJAKM-/GJANM-	1000001	9999999
GCV 530	GJAJM-/GJAMM-	1000001	9999999
GXV 50	GJAG-	1000001	9999999
GXV 120	GXV120-	1000001	9999999
GXV 140	GJAB-	6000001	9999999
GXV 160	GJ03-	1000001	5999999
GXV 160K1	GJ03-	6000001	9999999
GXV 270K1	GJ01-	2000001	9999999
GXV 340K1	GJ02-	1100001	5999999
GXV 340K2	GJ02-	6000001	9999999
GXV 390K1	GJAA-	6000001	9999999
GXV 520	GJAPM-	1000001	9999999
GXV 530	GJARM-	1000001	9999999
GXV 610	GJAC-	1000001	1999999
GXV 620	GJAD-	1000001	1999999
GXV 610K1	GJAC-	2000001	9999999
GXV 620K1	GJAD-	2000001	9999999
GXV 670	GJAH-	1000001	9999999

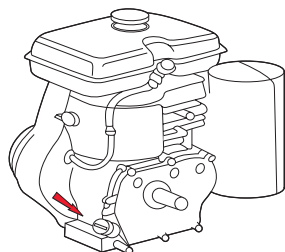

G 100/150/200

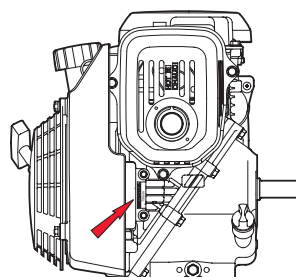

GC 135/160

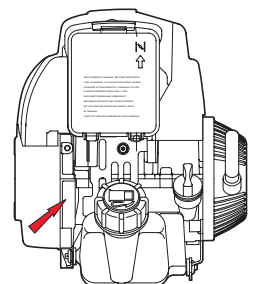

GX 22/31

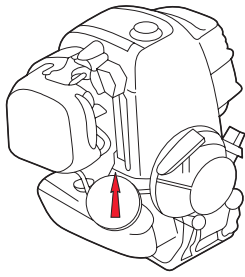

GX 25

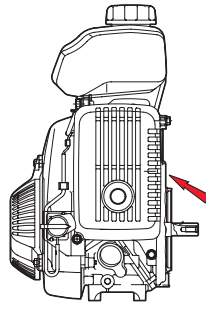

GXH 50

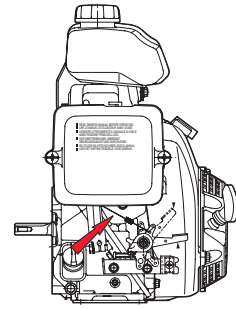

GX 100

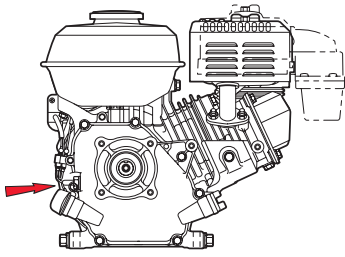

GX 120/160/200/240/270/340/390

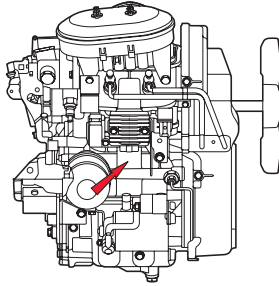

GX 360/640

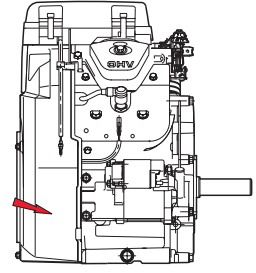

GX 610/620/670

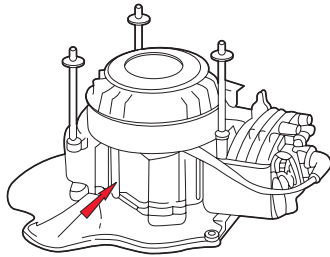

GV 100

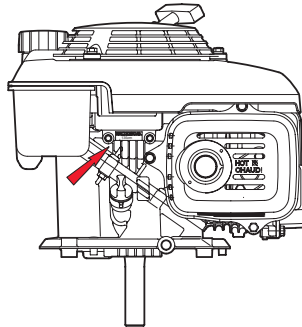

GCV 135/160

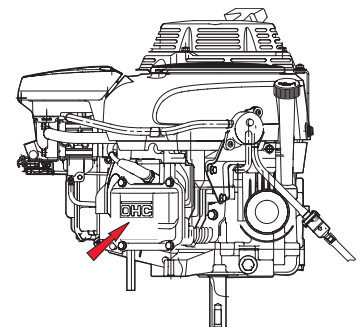

GCV 520/530

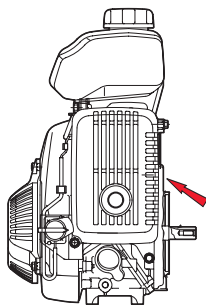

GXV 50

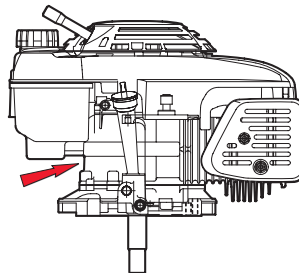

GXV 120/140/160

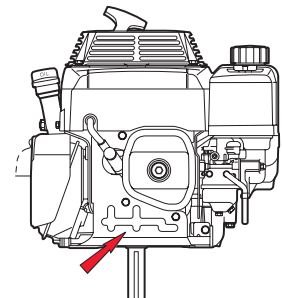

GXV 270/340

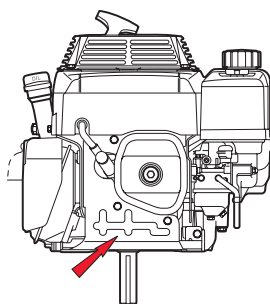

GXV 390

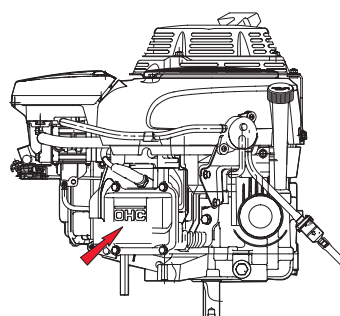

GXV 520/530

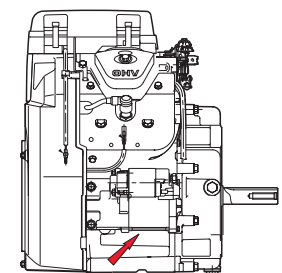

GXV 610/620/670

# Recoil starting system

Engine model	REF. 1	REF. 2	REF. 3	Reel diameter (mm)	REF. 4	REF. 5	REF. 6	REF. 7
	Starter ratchet	Return spring	Reel		Starter spring	Case comp.	Grip	Complete starter assy.
G 100K1	28422-896-010	28443-896-000	28420-ZG0-004	110	28442-ZE6-003	28410-ZG0-014ZB(RED)	28461-ZH8-003	28400-ZG0-004ZB(RED)
G 100K2						28410-ZG0-014ZB(RED)/ZA(BLACK)		28400-ZG0-004ZB(RED)/ZA(BLACK)
G 150	28422-883-020	-	28420-889-010	127	28442-883-000	28410-883-030H	28461-883-000	28400-883-040ZB
G 150K1	28422-883-T20	-	28421-883-T20	130	28442-883-T20	28410-883-T20ZA	28461-883-T20	28400-883-T20ZA
G 200	28422-883-020	-	28420-889-010	127	28442-883-000	28410-883-030ZB	28461-883-000	28400-883-040ZB
G 200K1	28422-883-T20	-	28421-883-T20	130	28442-883-T20	28410-883-T20ZA	28461-883-T20	28400-883-T20ZA
GC 135	-	-	-	-	-	-	28461-ZL8-003	28400-ZL8-013ZA(BLACK)/ZB(RED)
GC 160	-	-	-	-	-	-		
GX 22	-	-	28421-ZM3-003	60	28442-ZM3-003	28414-ZM3-003	28461-ZM3-003	28400-ZM3-003ZA
GX 31	-	-						
GX 25	-	-	28421-Z0H-003	50	28442-Z0H-003	28414-Z0H-003	28461-ZM3-003	28400-Z0H-003
GXH 50	-	-	28421-ZM7-003	75	-	28414-ZM7-003	28461-ZM3-003	28400-ZM7-003
GX 100 STD	-	-	-	-	-	-	28461-Z0D-003	28400-Z0D-003ZB(BLACK)/ZA(RED)
GX 100 TAMP	28422-ZG0-W02	-	28421-Z0D-V02	113	28442-ZH8-003	28410-Z0D-V02ZA	28461-ZH8-003	28400-Z0D-V02ZA
GX 120K1	28422-ZH8-013	28443-ZH8-003	28420-ZH8-013	137	28442-ZH8-003	28410-ZH8-003ZA(RED)/ZB(BLACK)	28461-ZH8-003	28400-ZH8-013ZA(RED)/ZB(BLACK)
GX 160K1								
GX 200								
GX 240K1	28422-ZE2-W01	28443-ZE2-W01	28421-ZE2-W01	150	28442-ZE2-W01	28410-ZE2-W01ZA(RED)/ZB(BLACK)	28461-ZE2-W01	28400-ZE2-W01ZA(RED)/ZB(BLACK)
GX 270							28461-ZE2-W02	
GX 340K1			28421-ZE3-W01	169		28410-ZE3-W01ZA(RED)/ZB(BLACK)	28461-ZE2-W01	28400-ZE3-W01ZA(RED)/ZB(BLACK)
GX 390K1							28461-ZE2-W02	
GX 360K1	NO RECOIL STARTER, ONLY WITH STARTER MOTOR							
GX 640								
GX 610	28422-ZE2-W01	28443-ZE2-W01	28421-ZE3-W01	169	28442-ZE2-W01	28410-ZE3-W01ZA(RED)/ZB(BLACK)	28461-ZE2-W01	28400-ZE3-W01ZA(RED)/ZB(BLACK)
GX 620						28410-ZE3-W01ZB(BLACK)	28461-ZE2-W02	28400-ZE3-W01ZB(BLACK)
GX 610K1						28410-ZE3-W01ZA(RED)/ZB(BLACK)		28400-ZE3-W01ZA(RED)/ZB(BLACK)
GX 620K1								28400-ZE3-W01ZA(RED)/ZB(BLACK)
GX 670	NO RECOIL STARTER, ONLY WITH STARTER MOTOR							
GV 100K1	28422-896-010	-	28420-ZG1-702	110	28442-ZE6-003	28410-ZG1-702ZA	28461-ZE7-T00	28400-ZG1-T12ZA(RED)/ZB(BLACK)
GV 100K2	28422-ZL1-003		28421-ZL1-003	110	28442-ZH8-003	-		28400-ZL1-003
GCV 135	-	-	-	-	-	-	28461-ZL8-003	28400-ZM0-632ZA(BLACK)
GCV 135E								
GCV 160A								28400-ZL8-013ZA(BLACK)/ZB(RED)
GCV 160								28400-ZM0-632ZA(BLACK)
GCV 520	NO RECOIL STARTER, ONLY WITH STARTER MOTOR							
GCV 530								
GXV 50	-	-	28421-ZM7-003	75	-	28414-ZM7-003	28461-ZM3-003	28400-ZM7-003
GXV 120	28422-896-010	28443-896-000	28420-ZE6-003	124	28442-ZE6-003	28410-ZE6-003ZA(RED)/ZB(BLACK)	28461-ZE1-003	28400-ZE6-003ZA(RED)/ZB(BLACK)
GXV 140	28485-ZE6-T02	28486-ZE6-T02	-	-	-	28402-ZG9-802	28461-ZE6-T02	28400-ZG9-803
GXV 160	28422-896-010	28443-896-000	28420-ZE7-003	120	28442-896-700	28410-ZE7-003ZA	28461-ZE1-003	28400-ZE7-003ZA
GXV 160K1	28485-ZE6-T02	28486-ZE6-T02	-	-	-	28402-ZG9-802	28461-ZE7-T00	28400-ZG9-N10
GXV 270K1	28422-ZE2-W01	28443-ZE2-W01	28421-ZE3-W01	169	28442-ZE2-W01	28410-ZE8-004ZB(RED)/ZA(BLACK)	28461-ZE2-W01	28400-ZE8-004ZB(RED)/ZA(BLACK)
GXV 340K1						28410-ZE8-004ZB(RED)		28400-ZE8-004ZB(RED)
GXV 340K2			28421-ZE8-821	165		28410-ZE3-W01ZA(RED)/ZB(BLACK)	28461-ZE2-W02	28400-ZE3-W01ZA(RED)/ZB(BLACK)
GXV 390K1			28421-ZE3-W01	169		28410-ZE3-W01ZA(RED)		28400-ZE3-W01ZA(RED)
GXV 520	NO RECOIL STARTER, ONLY WITH STARTER MOTOR							
GXV 530								
GXV 610	28422-ZE2-W01	28443-ZE2-W01	28421-ZE3-W01	169	28442-ZE2-W01	28410-ZE3-W01ZA(RED)/ZB(BLACK)	28461-ZE2-W02	28400-ZE3-W01ZA(RED)/ZB(BLACK)
GXV 620								
GXV 610K1						28410-ZE3-W01ZA(RED)		28400-ZE3-W01ZA(RED)
GXV 620K1						28410-ZE3-W01ZA(RED)/ZB(BLACK)		28400-ZE3-W01ZA(RED)/ZB(BLACK)
GXV 670	NO RECOIL STARTER, ONLY WITH STARTER MOTOR							



REF. 1



REF. 2



REF. 3



REF. 4



REF. 5



REF. 6



REF. 7

# Fuel system

Engine model	REF		
	Fuel tank cap	Ø in mm	
G 100K1, G 100K2, G 150K1, G 200K1, GX 120K1, GX 160K1, GX 200, GX 240K1, GX 270, GX 340K1, GX 390K1, GX 610	1bis	17620-ZH7-023	-
G 150, G 200	1bis	17620-883-T70	-
GX 120T1, GX 160T1, GX 200T	1a	17620-Z0T-811	-
GX 22, GX 31, GX 25	1	17620-ZM3-043	-
GXH 50	1	17620-ZL8-013	-
GX 620	1	17620-899-013	-
GX 620K1	1	17620-ZJ1-840	-
GV 100K1	1	17620-ZG1-000	-
GV 100K2, GXV 140	1	17620-ZG9-000	-
GXV 50	1	17620-ZV0-020	-
GXV 120, GXV 160, GXV 160K1, GXV 270K1, GXV 340K1, GXV 340K2, GXV 390K1	1	17620-ZE7-000	-
GC 135, GC 160, GX 100, GCV 135, GCV 160	1	17620-ZL8-013	-
Engine model		Fuel filter	Ø in mm
G 100K1, G 150, G 200	2	17672-880-000	34.5*
GX 22, GX 31, GX 25	3	17672-ZM3-003	16
GX 620, GX 620K1	2	17672-899-000	52*
GXV 270K1, GXV 340K2, GX 120K1, GX 160K1, GX 200, GX 240K1, GX 270, GX 340K1, GX 390K1, G 100K2, G 150K1, G 200K1	2	17672-ZE2-W01	32*
Engine model		Fuel cock	Ø in mm
GX 160K1, GX 200	4	16950-898-633	-
GX 620	4	16950-ZA0-013	-
GX 610, GX 620K1	4	16950-YA0-802	-
GV 100K2	5	16950-ZL1-000	-
GCV 135, GCV 160, GXV 140, GXV 50	5	16950-ZG9-M03	-
G 150, G 200	4	16950-883-663	-
G 150K1, G 200K1	4	16950-883-T03	-

\* = diameter of body fuel filter inside fuel tank



REF. 1bis



REF. 1a



REF. 1



REF. 2



REF. 3



REF. 4



REF. 5

# Gasket

Engine model	Gasket kit	Cylinder head gasket	Oil pan packing	Head cover packing	Exhaust pipe gasket
GV100K2	-	12281-ZC0-003	11381-ZL1-000	12375-ZG1-000	
GXV120	06111-ZE6-406	12251-ZE6-000	11381-ZG9-J60	12391-ZE7-M10	18381-ZE6-800
GXV140	06111-ZG9-406	12251-ZG9-000	11381-ZG9-T00	12391-ZE7-T00	18381-ZG9-M00
GXV160	06111-ZE7-406	12251-ZE7-000	11381-ZE7-M10	12391-ZE7-M10	
GXV160K1	061A1-ZE7-T00			12391-ZE7-T00	
GXV270K1	061A1-ZE8-U60	12251-ZE8-020	11381-ZE9-800	12391-ZE8-000	18333-ZE3-800
GXV340K1	-	12251-ZE9-600			
GXV340K2	06111-ZE9-V01				
GXV390K1	-	12251-ZF5-000			
G100K1	06111-ZG0-405	12281-ZG0-003	11381-ZG0-800	12375-ZG0-010	18381-ZG0-800
G100K2	06111-ZG0-406	12281-ZC0-003			
G150	061A1-887-S01	12281-887-306	11381-883-800	12375-887-000	18381-883-800
G150K1	-				
G200	061A1-883-S01	12281-883-801		12375-883-000	
G200K1	-				
GX120K1	06111-ZH7-405	12251-ZH7-800	11381-ZH7-800	12391-ZE1-000	18382-ZH8-800
GX160K1	06111-ZH8-405	12251-ZF1-800	11381-ZH8-801		
GX200	06111-ZL0-000	12251-ZL0-003	11381-ZL0-000		
GX240K1	06111-ZE2-408	12251-ZE2-800	11381-ZE2-801	12391-ZE2-020	18382-ZE2-800
GX270	06111-ZH9-050	12251-ZH9-000			
GX340K1	06112-ZE3-405	12251-ZE3-W00	11381-ZE3-801		
GX390K1	06111-ZF6-R81	12251-ZF6-W00			
GX610 / 620	061A1-ZJ1-000	12251-ZJ1-003	11381-ZJ1-000	12391-ZJ1-000	18333-ZJ1-000
GX610 / 620 K1	061A1-ZJ1-001	12251-ZJ1-841	11381-ZJ1-840	12391-ZE2-020	18333-ZE3-800

*Important: Oil seals for crankshaft and flywheel are not included in the gasket kit*

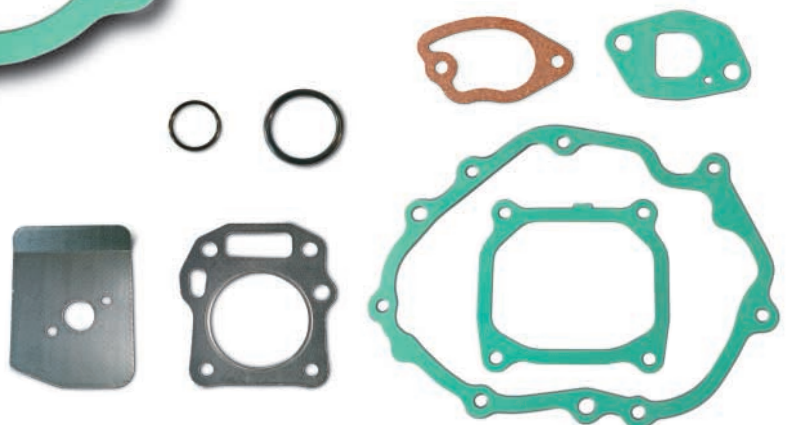
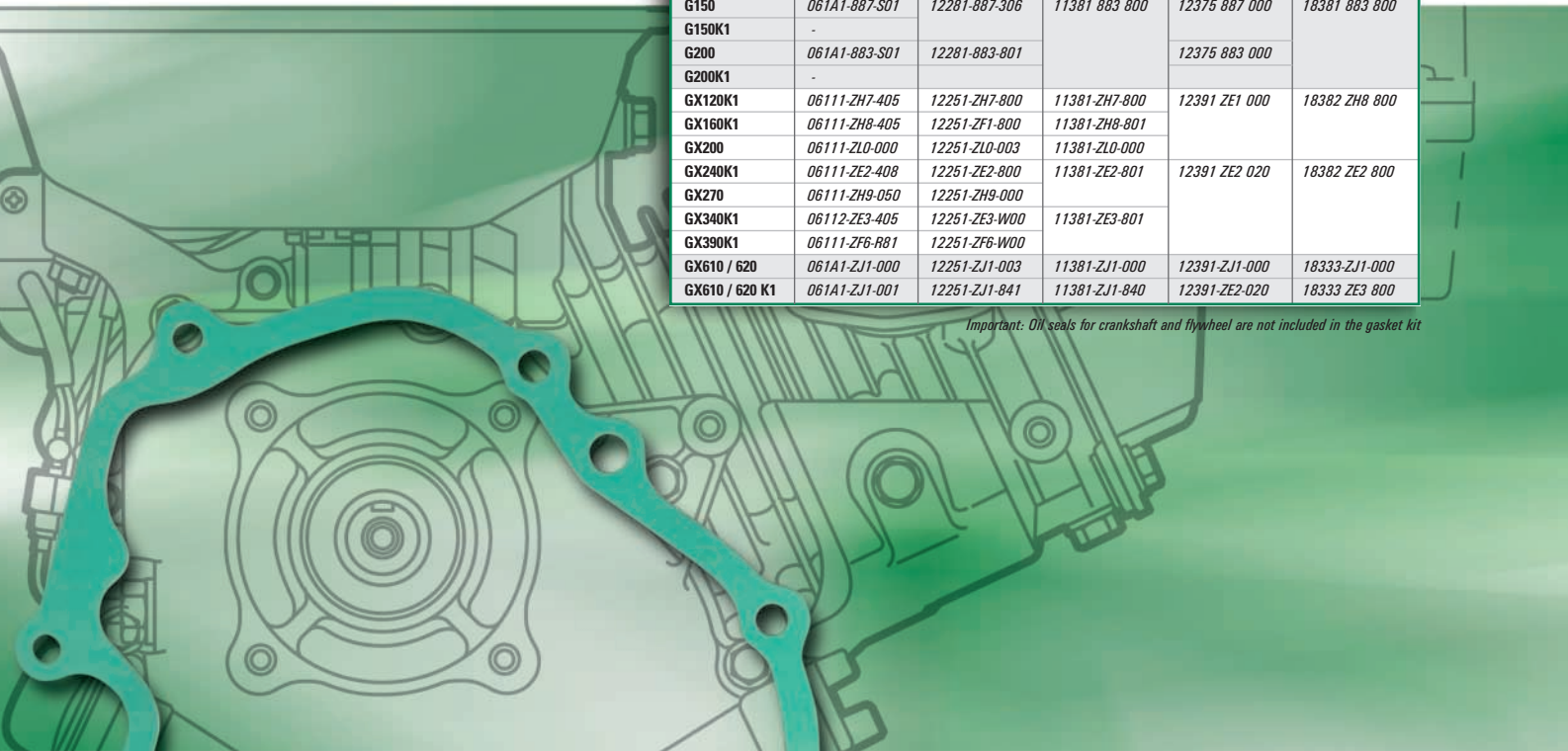

# Piston

Engine model	REF 1	Bore diameter in mm	REF 2	REF 3	REF 4	REF 5	con.rod (-025)
	Piston		Ring set	Piston pin	Piston clip	con.rod std	
G 100K1	13101-Z60-003*	48	13010-Z60-003*	13111-892-000	13115-147-000	13200-Z60-000	13200-Z60-305
G 100K2	13101-ZC0-003*		13010-ZC0-003*	13111-892-000	13115-147-000	13200-Z60-000	
G 150	13101-887-003*	64	13010-887-000*	13111-883-000	90551-883-000	13200-887-010	13200-887-315
G150K1						13200-887-050	-
G 200	13101-883-003*	67	13010-883-003*			13200-883-040	13200-883-345
G 200K1							
GC 135	13101-ZL8-000	64	13010-ZL8-003	13111-ZE0-000	90551-ZE0-000	13200-ZL9-000	-
GC 160						13200-ZL8-000	-
GX 22	13101-ZM3-020	33	13010-ZM3-000	13111-ZM3-000	-	-	-
GX 31	13101-ZM5-020	39	13010-ZM5-000	13111-ZM5-000			
GX 25	13101-Z0H-000	35	13010-Z0H-000	13111-Z0H-000			
GXH 50	13101-ZM7-000	41,8	13010-ZM7-000	13111-122-000	13115-147-000	13200-ZM7-000	-
GX 100 STD	13101-Z0D-000	56	13010-Z0D-003	13111-ZE0-000	90551-ZE0-000	13200-Z0D-000	13200-Z0D-305
GX 100 TAMP							
GX 120K1	13101-ZH7-000*	60	13010-ZK7-V01*	13111-ZE0-000	90551-ZE0-000	13200-ZE0-000	-
GX 160K1	13101-ZH8-010*	68	13010-ZH8-941*	13111-ZE1-000	90551-ZE1-000	13200-ZE1-010	-
GX 200	13101-ZL0-000*	68	13010-ZL0-003*	13111-ZE1-000	90551-ZE1-000	13200-ZE1-010	132A0-ZE1-000
GX 240K1	13101-ZE2-W00*	73	13010-ZE2-013*	13111-ZE2-000	90551-ZE1-000	13200-ZE2-010	13200-ZE2-305
GX 270	13101-ZH9-000*	77	13010-ZE8-601*		90551-ZE1-000	13200-ZE2-000	
GX 340K1	13101-ZE3-W00*	82	13010-ZE3-003*	13111-ZF6-000	90601-ZE3-000	13200-ZE3-010	13200-ZE3-315
GX 390K1	13101-ZF6-W00*	88	13010-ZF6-003*	13111-ZF6-W00	90601-ZE3-000	13200-ZE3-020	
GX 360K1	13101-ZA0-000*	58	130A1-ZA0-004*	13111-881-000	94601-14000	13210-ZA0-000	-
GX 640	13101-Z68-000*	76	13010-Z68-004*	13111-Z68-000	94601-19000	13210-Z68-000	-
GX 610	13101-ZJ1-000*	77	13010-ZE8-601*	13111-ZJ1-000	90551-ZE1-000	13210-ZJ1-000	-
GX 620							
GX 610K1	13101-ZJ1-840*		13010-ZJ1-841*	13111-ZJ1-840	94601-18000	13200-ZJ1-841	
GX 620K1							
GX 670	13101-ZN1-000*					13200-ZN1-003	
GV 100K1	13101-ZC0-003	52	13010-ZG1-U11	13111-892-000	13115-147-000	13200-ZG0-000	-
GV 100K2							
GCV 135	13101-ZL8-000	64	13010-ZL8-003	13111-ZE0-000	90551-ZE0-000	13200-ZL8-000	-
GCV 135E							
GCV 160A							
GCV 160							
GCV 520	13101-Z0A-000	77	13010-Z0A-014	13111-ZJ1-840	90551-ZE1-000	13200-Z0A-003	-
GCV 530	13101-Z0A-800		13010-ZJ1-841		90551-ZE1-000	13200-Z0A-003	
GXV 50	13101-ZM7-000	41,8	13010-ZM7-000	13111-122-000	13115-147-000	13200-ZN4-000	-
GXV 120	13101-ZE6-003*	60	13010-ZE6-003*	13111-ZJ1-840	90551-ZE1-000	13200-Z0A-003	-
GXV 140	13101-Z69-000*	64	13010-Z69-003*	13111-ZE0-000	90551-ZE0-000	13200-ZE6-010	
GXV160	13101-ZE7-000*	68	13010-ZF1-014*	13111-ZE1-000	90551-ZE1-000	13200-ZE7-000	13200-ZE7-305
GXV 160K1	13101-ZE7-010*		13010-ZF1-023*		90551-ZE1-000	13200-ZE7-000	-
GXV 270K1	13101-ZE8-010*	77	13010-ZE8-601*	13111-ZE2-000	90551-ZE1-000	13200-ZE8-000	13200-ZE8-305
GXV 340K1	13101-ZE3-000*	82	13010-ZE3-003*	13111-ZE3-000	90601-ZE3-000	13200-ZE9-010	13200-ZE9-315
GXV 340K2	13101-ZE3-W00*						
GXV 390K1	13101-ZF6-W00*	88	13010-ZF6-003*	13111-ZF6-000			
GXV 520	13101-Z0A-000	77	13010-Z0A-003	13111-ZJ1-840	90551-ZE1-000	13200-Z0A-801	-
GXV 530							
GXV 610	13101-ZJ1-000*	77	13010-ZE8-601*	13111-ZJ1-000	90551-ZE1-000	13210-ZJ1-000	-
GXV 620							
GXV 610K1	13101-ZJ1-840*		13010-ZJ1-841*	13111-ZJ1-840	94601-18000	13200-ZJ1-841	
GXV 620K1							
GXV 670	13101-ZN1-000*		13010-ZJ1-841*	13111-ZJ1-840		13200-ZN1-003	

\* = oversize pistons/rings sets are available



# Ignition coil

Engine model	REF.	Ignition coil	Centre dist coil in mm	Coil thickness in mm	Cord length in mm
G 100K1	1	30500-ZG0-813	57	12	245
G 100K2	1	30500-ZG0-W01	56	12	250
G 150	3	30560-887-100	74	12	300
G 150K1	1	30500-883-R51	58	12	360
G 200	3	30560-883-015	75	12	340
G 200K1	1	30500-883-R51	58	12	360
GC 135	1	30500-ZL8-004	58	9	150
GC 160					
GX 22	1	30500-ZM3-003	33	8	230
GX 31					
GX 25	1	30500-Z0H-003	35	6	29
GXH 50	1	30500-ZM7-004	30	9	120
GX 100 STD	1	30500-Z0D-003	62	6	110
GX 100 TAMP	1	30500-Z0D-V01	60,5	6	115
GX 120K1	2	30500-ZE1-043	58	12	200
GX 160K1					
GX 200					
GX 240K1	2	30500-ZF6-W02	68	12	250
GX 270					
GX 340K1					
GX 390K1					
GX 360K1	5	30500-ZA0-701 (CYL. 1 + CYL. 2)	72	15	250/310
GX 640	3	30500-ZG8-003 (CYL. 1 + CYL. 2)	-	-	175/200
GX 610	2	30500-ZJ1-023(CYL.1)/30550-ZJ1-023(CYL.2)	58	12	160/200
GX 620					
GX 610K1	2	30500-ZJ1-842(CYL.1)/30550-ZJ1-842(CYL.2)	58	18	180/200
GX 620K1					
GX 670					
GV 100K1	1	30500-ZG1-U10	56	12	200
GV 100K2		30500-ZL1-004	56	9	140
GCV 135	1	30500-ZL8-004	58	9	150
GCV 135E					
GCV 160A					
GCV 160					
GCV 520	1	30500-Z0A-013(CYL.1)/30550-Z0A-013(CYL.2)	58	12	160/200
GCV 530					
GXV 50	1	30500-ZM7-004	30	9	120
GXV 120	2	30500-ZG9-M03	58	12	110
GXV 140	1	30500-ZG9-801	62	9	170
GXV160	2	30500-ZE7-043	58	12	120
GXV 160K1	2	30500-ZG9-801	62	9	170
GXV 270K1	2	30500-ZF5-003	68	12	210
GXV 340K1	2	30500-ZE9-L33	68	12	235
GXV 340K2					
GXV 390K1					
GXV 520	1	30500-Z0A-013(CYL.1)/30550-Z0A-013(CYL.2)	58	12	160/200
GXV 530					
GXV 610	2	30500-ZJ1-023(CYL.1)/30550-ZJ1-023(CYL.2)	58	12	160/200
GXV 620					
GXV 610K1	2	30500-ZJ1-842(CYL.1)/30550-ZJ1-842(CYL.2)	58	18	180/200
GXV 620K1					
GXV 670					



REF. 1



REF. 2



REF. 3



REF. 4



REF. 5



# Aircleaner

Engine model	REF.	Aircleaner	Outer filter	dimensions			material/shape
				long.	width	height	
G 100K1, G100K2	1	17211-896-000		94	76	25	urethane, rectangle
G 150, G 200	2	17211-883-010		120	120	40	urethane, round
G 150K1, G 200K1	3	17211-883-W21	17218-883-W21	178	89	29	paper, rectangle
GC 135, GC 160, GCV 135/160	3	17211-ZL8-003		133	115	21	paper, rectangle
GX 25	4	17211-ZOH-000		76	83	20	urethane, +/- oval
GX 22, GX 31	5	17211-ZM3-000		72	72	20	urethane, round
GXH 50, GXV 50	1	17211-ZM7-000		89	89	12	urethane, square
GX 100 STD, GX 100 TAMPER	3	17211-ZL8-003	17218-ZOD-000	133	115	21	paper, rectangle
GX 120K1	6	17210-ZE0-505*	17218-ZE0-505	102	74	52	paper, oval(out filt.urethane)
GX 160K1, GX 200	6	17210-ZE1-505*	17218-ZE1-505	102	74	71	paper, oval(out filt.urethane)
GX 240K1, GX 270	6	17210-ZE2-505*	17218-ZE2-505	155	121	40	paper, oval(out filt.urethane)
GX 340K1, GX 390K1	6	17210-ZE3-505*	17218-ZE3-505	112	97	92	paper, oval(out filt.urethane)
GX 360K1	6	17210-ZA0-506	17218-ZA0-506	165	105	40	paper, oval(out filt.urethane)
GX 640	7	06172-ZG8-L20	17218-ZG8-000	186	174	34	paper, rectangle
GX 610, GX 620, GXV 610, GXV 620	7	17010-ZJ1-000	17218-ZJ1-000	238	183	32	paper, rectangle
GX 610K1, GX 620K1, GX 670, GXV 610K1, GXV 620K1, GXV 670	8	17210-ZJ1-842	17218-ZJ1-840	225	167	30	paper, rectangle
GV 100K1	9	17211-ZG1-700		130	75	25	urethane, +/--rectangle
GV 100K2	9	17211-ZL1-000		120	70	25	urethane, +/--rectangle
GCV 520, GCV 530, GXV 520, GXV 530	8	17211-ZOA-003	17218-ZOA-000	215	120	22	paper, rectangle
GXV 120	6	17210-ZE6-505*	17218-ZE6-505	190	62	50	paper, oval(out filt.urethane)
GXV 140	7	17211-ZG9-800	17218-ZG9-800	137	61	25	paper, rectangle
GXV 160	6	17210-ZE7-505*	17218-ZE6-505	190	63	45	paper, oval(out filt.urethane)
GXV 160K1	6	17211-ZE7-W03*	17218-ZE7-W02	180	62	50	paper, oval(out filt.urethane)
GXV 270K1, GXV 340K1	6	17210-ZF5-505	17218-ZF5-505	124	60	87	paper, oval
GXV 340K2, GXV390K1	6	17211-ZF5-V01	17218-ZF5-V00	124	60	87	paper, oval

\* = aircleaner + outer filter



REF. 1



REF. 2



REF. 3



REF. 4



REF. 5



REF. 6



REF. 7



REF. 8



REF. 9

# Oilfilter



Oilfilter

Engine model	Oilfilter	Ø	height	Material
GXV 340K2, GXV 610, GXV 610K1, GXV 620, GXV 620K1, GXV 670, GX 610, GX 610K1, GX 620, GX 620K1, GX 670	15400-ZJ1-004	83	82	metal, cyl.
GCV 520, GCV 530, GXV 520, GXV 530	15400-PFB-004	65	65	metal, cyl.
GX 640	15400-PFB-007	69	72	metal, cyl.
GXV 340K1, GXV 390	15400-PLC-004	65	85	metal, cyl.
GX 360K1	15400-679-033	68	67	metal, cyl.



# Fuel strainer



Fuel strainer

Engine model	Fuel strainer	Small Ø	Big Ø	Height	Material
GCV 530, GC 135, GC 160, GXV 520, GXV 530	16910-ZV4-015	22	29	67	plastic
GX 100, GX 120K1, GX 160K1, GX 200, GX 240K1, GX 270, GX 360K1, GX 390K1	16910-GB2-005	23	30	53	plastic
GXV 340K1, GXV 340K2, GXV 390K1, GXV 610, GXV 610K1, GXV 620, GXV 620K1, GXV 670, GX 360K1, GX 610, GX 610K1, GX 620, GX 620K1, GX 670, G 100K1, G 100K2, GXV 270K1	16910-ZE9-015	22	29	65	plastic
G 100K2	16910-ZG0-U02	22	29	64	plastic

# Service kit

Engine model	Service kit	Quantity
GC-GCV 135/160	06211-ZL8-000 06211-ZL8-000MP	1 multipack of 1x12



# 4-stroke oil

Engine model	4-stroke oil	Quantity
All engines	08221-99953HD 4 stroke oil 10W30 SJ/SH	25 x 0.1 L
	08221-99955HD 4 stroke oil 10W30 SJ/SH	8 x 0.6 L
	08221-99957HD 4 stroke oil 10W30 SJ/SH	6 x 1 L
	08221-99959HD 4 stroke oil 10W30 SJ/SH	1 x 20 L



25 x 0.1 L



8 x 0.6 L



6 x 1 L



1 x 20 L



**Honda Europe NV**  
Langerbruggestraat 104  
B-9000 Gent